



INTERNATIONAL STANDARD

ISO 1206

Third edition
2001-11-15

Rolling bearings — Needle roller bearings, dimension series 48, 49 and 69 — Boundary dimensions and tolerances

*Roulements — Roulements à aiguilles, séries de dimensions 48, 49 et 69 —
Dimensions d'encombrement et tolérances*



Reference number
ISO 1206:2001(E)

© ISO 2001

PDF disclaimer

This PDF file may contain embedded typefaces. In accordance with Adobe's licensing policy, this file may be printed or viewed but shall not be edited unless the typefaces which are embedded are licensed to and installed on the computer performing the editing. In downloading this file, parties accept therein the responsibility of not infringing Adobe's licensing policy. The ISO Central Secretariat accepts no liability in this area.

Adobe is a trademark of Adobe Systems Incorporated.

Details of the software products used to create this PDF file can be found in the General Info relative to the file; the PDF-creation parameters were optimized for printing. Every care has been taken to ensure that the file is suitable for use by ISO member bodies. In the unlikely event that a problem relating to it is found, please inform the Central Secretariat at the address given below.

© ISO 2001

All rights reserved. Unless otherwise specified, no part of this publication may be reproduced or utilized in any form or by any means, electronic or mechanical, including photocopying and microfilm, without permission in writing from either ISO at the address below or ISO's member body in the country of the requester.

ISO copyright office
Case postale 56 • CH-1211 Geneva 20
Tel. + 41 22 749 01 11
Fax + 41 22 749 09 47
E-mail copyright@iso.ch
Web www.iso.ch

Printed in Switzerland

Foreword

ISO (the International Organization for Standardization) is a worldwide federation of national standards bodies (ISO member bodies). The work of preparing International Standards is normally carried out through ISO technical committees. Each member body interested in a subject for which a technical committee has been established has the right to be represented on that committee. International organizations, governmental and non-governmental, in liaison with ISO, also take part in the work. ISO collaborates closely with the International Electrotechnical Commission (IEC) on all matters of electrotechnical standardization.

International Standards are drafted in accordance with the rules given in the ISO/IEC Directives, Part 3.

Draft International Standards adopted by the technical committees are circulated to the member bodies for voting. Publication as an International Standard requires approval by at least 75 % of the member bodies casting a vote.

Attention is drawn to the possibility that some of the elements of this International Standard may be the subject of patent rights. ISO shall not be held responsible for identifying any or all such patent rights.

International Standard ISO 1206 was prepared by Technical Committee ISO/TC 4, *Rolling bearings*, Subcommittee SC 5, *Needle roller bearings*.

This third edition cancels and replaces the second edition (ISO 1206:1982), which has been technically revised.



Rolling bearings — Needle roller bearings, dimension series 48, 49 and 69 — Boundary dimensions and tolerances

1 Scope

This International Standard specifies the boundary dimensions and normal class tolerances for needle roller bearings of dimension series 48, 49 and 69 as given in ISO 15. These series apply to complete needle roller bearings and to bearings without inner ring.

This International Standard does not apply to drawn cup needle roller bearings.

2 Normative references

The following normative documents contain provisions which, through reference in this text, constitute provisions of this International Standard. For dated references, subsequent amendments to, or revisions of, any of these publications do not apply. However, parties to agreements based on this International Standard are encouraged to investigate the possibility of applying the most recent editions of the normative documents indicated below. For undated references, the latest edition of the normative document referred to applies. Members of ISO and IEC maintain registers of currently valid International Standards.

ISO 582:1995, *Rolling bearings — Chamfer dimensions — Maximum values*

ISO 1132-1:2000, *Rolling bearings — Tolerances — Part 1: Terms and definitions*

ISO 5593:1997, *Rolling bearings — Vocabulary*

ISO 5753:1991, *Rolling bearings — Radial internal clearance*

ISO 15241:2001, *Rolling bearings — Symbols for quantities*

3 Terms and definitions

For the purposes of this International Standard, the terms and definitions given in ISO 1132-1 and ISO 5593 apply.

For the purposes of this International Standard the symbols given in ISO 15241 and the following apply.

The symbols (except those for tolerances) shown in Figures 1 and 2, and the values given in Tables 1 to 6 denote nominal dimensions unless specified otherwise.

B	inner ring width
C	outer ring width
d	bore diameter
D	outside diameter
F_w	bore diameter of needle roller complement
$F_{ws\ min}$	smallest single bore diameter of needle roller complement ¹⁾
K_{ea}	radial runout of outer ring of assembled bearing
K_{ia}	radial runout of inner ring of assembled bearing
r	chamfer dimension
$r_{s\ min}$	smallest single chamfer dimension
V_{Bs}	variation of inner ring width
V_{Cs}	variation of outer ring width
V_{dmp}	variation of mean bore diameter
V_{Dmp}	variation of mean outside diameter
Δ_{Bs}	deviation of a single inner ring width
Δ_{Cs}	deviation of a single outer ring width
Δ_{dmp}	deviation of mean bore diameter in a single plane
Δ_{Dmp}	deviation of mean outside diameter in a single plane

1) The smallest single bore diameter of the needle roller complement is the diameter of the cylinder which, when placed in the needle roller complement bore, results in zero radial clearance in at least one radial direction.

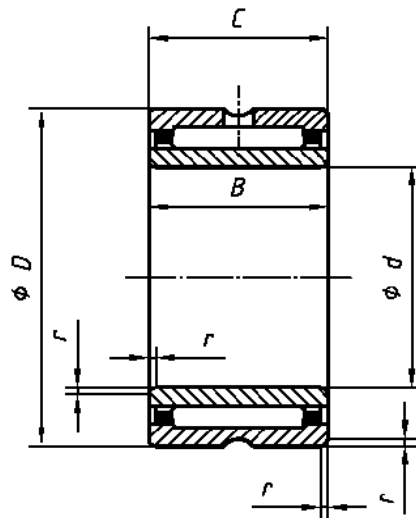

NOTE Needle roller bearings can be equipped with or without cage, with one row or two rows of needle roller and with or without lubrication groove and lubrication holes in the outer ring.

Figure 1 — Complete needle roller bearing

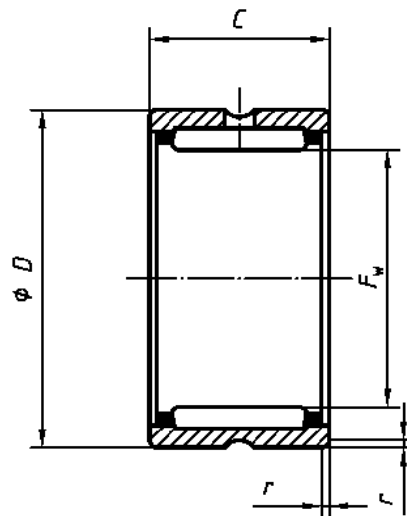

NOTE Needle roller bearings can be equipped with or without cage, with one row or two rows of needle roller and with or without lubrication groove and lubrication holes in the outer ring.

Figure 2 — Needle roller bearing without inner ring

Boundary dimensions for dimension series 48, 49 and 69 are given in Tables 1, 2 and 3, respectively.

Table 1 — Dimension series 48

Dimensions in millimetres

Complete bearings and bearings without inner ring				
d	F_w	D	B and C	$r_{s \min}^a$
110	120	140	30	1
120	130	150	30	1
130	145	165	35	1,1
140	155	175	35	1,1
150	165	190	40	1,1
160	175	200	40	1,1
170	185	215	45	1,1
180	195	225	45	1,1
190	210	240	50	1,5
200	220	250	50	1,5
220	240	270	50	1,5
240	265	300	60	2
260	285	320	60	2
280	305	350	69	2
300	330	380	80	2,1
320	350	400	80	2,1
340	370	420	80	2,1
360	390	440	80	2,1

^a Maximum chamfer dimensions are given in ISO 582.

Table 2 — Dimension series 49

Dimensions in millimetres

Complete bearings and bearings without inner ring				
d	F_w	D	B and C	$r_{s \min}^a$
5	7	13	10	0,15
6	8	15	10	0,15
7	9	17	10	0,15
8	10	19	11	0,2
9	12	20	11	0,3
10	14	22	13	0,3
12	16	24	13	0,3
15	20	28	13	0,3
17	22	30	13	0,3
20	25	37	17	0,3
22	28	39	17	0,3
25	30	42	17	0,3
28	32	45	17	0,3
30	35	47	17	0,3
32	40	52	20	0,6
35	42	55	20	0,6
40	48	62	22	0,6
45	52	68	22	0,6
50	58	72	22	0,6
55	63	80	25	1
60	68	85	25	1
65	72	90	25	1
70	80	100	30	1
75	85	105	30	1
80	90	110	30	1
85	100	120	35	1,1
90	105	125	35	1,1
95	110	130	35	1,1
100	115	140	40	1,1
110	125	150	40	1,1
120	135	165	45	1,1
130	150	180	50	1,5
140	160	190	50	1,5

^a Maximum chamfer dimensions are given in ISO 582.

Table 3 — Dimension series 69

Dimensions in millimetres

Complete bearings and bearings without inner ring				
d	F_w	D	B and C	$r_{s, \min}^a$
10	14	22	22	0,3
12	16	24	22	0,3
15	20	28	23	0,3
17	22	30	23	0,3
20	25	37	30	0,3
22	28	39	30	0,3
25	30	42	30	0,3
28	32	45	30	0,3
30	35	47	30	0,3
32	40	52	36	0,6
35	42	55	36	0,6
40	48	62	40	0,6
45	52	68	40	0,6
50	58	72	40	0,6
55	63	80	45	1
60	68	85	45	1
65	72	90	45	1
70	80	100	54	1
75	85	105	54	1
80	90	110	54	1
85	100	120	63	1,1
90	105	125	63	1,1
95	110	130	63	1,1
100	115	140	71	1,1

^a Maximum chamfer dimensions are given in ISO 582.

Tolerances for dimension series 48, 49 and 69 are given in Tables 4, 5 and 6, respectively.

Table 4 — Inner ring

Tolerance values in micrometres

d mm		Δ_{dmp}		V_{dmp}	K_{ia}	Δ_{Bs}		V_{Bs}
>	\leq	high	low	max.	max.	high	low	max.
2,5	10	0	-8	6	10	0	-120	15
10	18	0	-8	6	10	0	-120	20
18	30	0	-10	8	13	0	-120	20
30	50	0	-12	9	15	0	-120	20
50	80	0	-15	11	20	0	-150	25
80	120	0	-20	15	25	0	-200	25
120	180	0	-25	19	30	0	-250	30
180	250	0	-30	23	40	0	-300	30
250	315	0	-35	26	50	0	-350	35
315	400	0	-40	30	60	0	-400	40

Table 5 — Outer ring

Tolerance values in micrometres

D mm		Δ_{Dmp}		V_{Dmp}	K_{ea}	Δ_{Cs}	V_{Cs}
>	\leq	high	low	max.	max.		
6	18	0	-8	6	15	Identical to Δ_{Bs} and V_{Bs} of inner ring ^a of same bearing	
18	30	0	-9	7	15		
30	50	0	-11	8	20		
50	80	0	-13	10	25		
80	120	0	-15	11	35		
120	150	0	-18	14	40		
150	180	0	-25	19	45		
180	250	0	-30	23	50		
250	315	0	-35	26	60		
315	400	0	-40	30	70		
400	500	0	-45	34	80		

^a For bearings without inner ring the values for the corresponding bearing with inner ring apply.

Table 6 — Bore diameter of needle roller complement for bearings without inner ring

Tolerance values in micrometres

F_w mm		Tolerances for $F_{ws\ min}^a$	
>	≤	high	low
3	6	+18	+10
6	10	+22	+13
10	18	+27	+16
18	30	+33	+20
30	50	+41	+25
50	80	+49	+30
80	120	+58	+36
120	180	+68	+43
180	250	+79	+50
250	315	+88	+56
315	400	+98	+62

NOTE The tolerance values are valid on condition that the variation in a single radial plane of the outer ring bore diameter be kept small in relation to the tolerance range for the minimum diameter $F_{ws\ min}$.

^a The values in the table give the limits of the difference between $F_{ws\ min}$ and F_w .

7 Radial internal clearance

Radial internal clearance of complete bearings is the arithmetical mean of the radial distances through which one of the rings may be displaced relative to the other, from one eccentric extreme position to the diametrically opposite extreme position, in different angular directions and without being subjected to any external load.

Values for radial internal clearance of complete bearings are given in ISO 5753.



Bibliography

- [1] ISO 15:1998, *Rolling bearings — Radial bearings — Boundary dimensions, general plan*

ISO 1200

标准分享站
anystandards.com

ICS 21.100.20

Price based on 9 pages

© ISO 2001 All rights reserved